

INSTALLATION INSTRUCTIONS

READ THOROUGHLY BEFORE BEGINNING

6390 RAIL KIT - 2002 DODGE RAM 1500 Pickup. For use with Draw-Tite Gooseneck Hitch – Part Number 6300, 8311, 8315 & 8339

IMPORTANT

This product is intended for installation on 2002 and later DODGE RAM 1500 pickup. For use with Draw-Tite Gooseneck Hitch Part Number 6300, 8311, 8315 & 8339. This installation instruction describes the installation of the Draw-Tite Rail Kit 6390 and Gooseneck Hitch 6300, 8311, 8315 & 8339. Give this installation instruction to vehicle owner after installation is complete.

-THE MAXIMUM RATING-

DO NOT EXCEED VEHICLE MANUFACTURER'S RATING FOR 5th WHEEL TOWING

TOOLS REQUIRED:

- Hand drill
- Drill bits - 1/4" (.250), 17/32" (.531), 5/8" (.625), 3/4" (.750)
- Sockets and wrenches - 9/16, 7/8, 15/16, 1-1/8
- Center punch
- Torque wrench
- Saber saw
- Files - round & flat
- Hammer
- Tape
- Hole saw – 3-1/2"

PARTS LIST:

- Forward cross angle P/N 100132
- Rear cross angle P/N 100133
- Driver's side bracket P/N 100130
- Passenger Side bracket P/N 100131
- Fastener Kit P/N F6390

- 1/2-13 X 1.75 GR5 CARRIAGE BOLT
- 1/2 CONICAL WASHER
- 1/2 HEX LOCKNUT

- (6) 1/4" X 2" X 1" GREEN SHIMS INSTALLATION SEE STEP 16 (P/N 5994)

- (6) 3/16" X 2" X 1" GOLD SHIMS INSTALLATION SEE STEP 16 (P/N 5971)

- 1/2 HEX NUT HEAVY
- 1/2 LOCK WASHER
- 1/4 X 1-1/2 X 2 BLOCK (P/N 1097-002)
- 1/2-13 X 1.50 GR5 RIBBED NECK BOLT BOTH SIDES

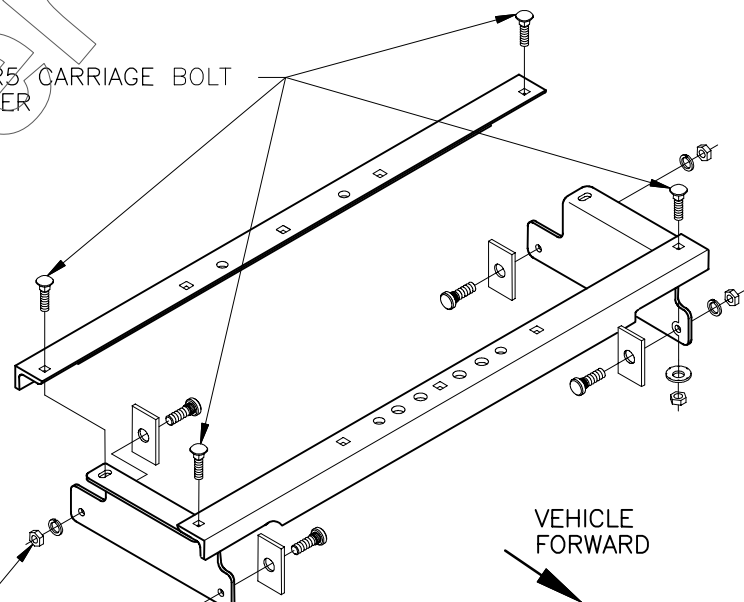

NOTE: CHECK HITCH FREQUENTLY, MAKING SURE ALL FASTENERS ARE PROPERLY TIGHTENED. A HITCH OR BALL WHICH HAS BEEN DAMAGED SHOULD BE REMOVED AND REPLACED. OBSERVE SAFETY PRECAUTIONS WHEN WORKING BENEATH A VEHICLE AND WEAR EYE PROTECTION. FOLLOW VEHICLE MAKER'S SPECIFICATIONS FOR MAXIMUM TRAILER WEIGHT. DO NOT CUT ACCESS OR ATTACHMENT HOLES WITH A TORCH.

INSTALLATION INSTRUCTIONS:

For Reference Only

WARNING Fuel lines, brake lines and electrical wires are located along the inside of the driver's side frame rail. The hanger(s) for lines will need to be loosened and/or moved during the installation. Be careful not to kink, puncture or damage these lines. After installation, do not allow these lines to rub against any of the side bracket fasteners. When enlarging attaching holes, examine the back side of the frame before drilling to be sure there are no lines, wires or fuel tank that can be damaged when drill breaks through the frame. If a fuel tank is on the back side, a shield of wood or metal must be used to protect the fuel tank from being punctured.

TRAILER/VEHICLE CLEARANCE DETERMINATION:

Before beginning installation, measure your Gooseneck trailer to determine that your trailer will have adequate clearance to your tow vehicle. Measure from the center of the coupler to the nearest vertical component on your trailer that could swing during a turn and contact your tow vehicle. Record this dimension (A) _____. Measure from the center of the coupler diagonally to the forward corner of the trailer nose, this part of the trailer could contact your cab during a turn. Record this dimension (B) _____.

If (A) measures less than (A) listed on the chart below, trailer will contact tow vehicle and hitch should not be installed.
 If (B) measures more than (B) listed on the chart below, trailer will contact tow vehicle and hitch should not be installed.

- Ram w/8' Bed (A) = 60"
(B) = 65"
- Ram w/6' Bed (A) = 60"
(B) = 46"

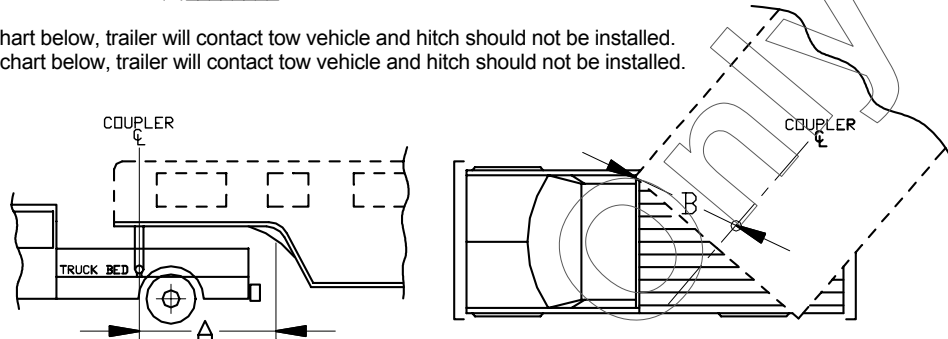

NOTE: The measurements above are guidelines. If your measurements are close to these numbers re-check clearances. If vehicle and/or trailer has any added bed vicinity accessories (i.e. fairings, airdams, ground effects, bed rails, etc.), Added dimensioning and clearance checks have to be made.

6300, 8311 & 8339 INSTALLATION (for 8315 installation go to page 5)

NOTE: Assemble ball in 8311 gooseneck (page 4, step 21) prior to installing gooseneck in vehicle bed.

CROSS ANGLE INSTALLATION:

1. Loosen bed.
2. Place a 1/2-13 x 1.75 GR5 (Grade 5) carriage bolt in each of the outermost square holes in the cross angles. It may be helpful to tape the carriage bolt heads to the cross angles during this step of installation.
3. Slide cross angles between bed and frame.

SIDE BRACKET INSTALLATION:

4. Loosely attach the side brackets to the cross angles with the 1/2" conical washers and nuts.
5. Locate the cross angles and side brackets as shown in figure below left.

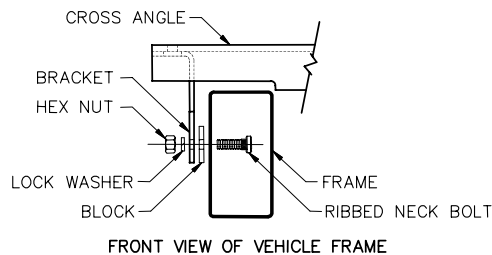
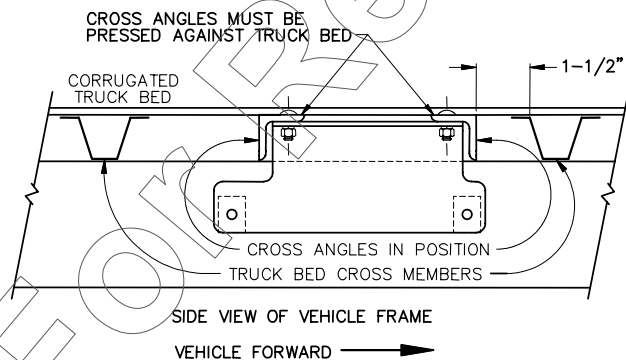

6. Using the side bracket as a template drill two 17/32" holes thru the side of frame.
7. With block P/N.1097-002 sandwiched between vehicle frame and bracket, fishwire (a fishwire lengthened to 36" long will be required) 1/2" ribbed neck bolts thru round access hole in bottom of frame and then thru frame, block and bracket as shown in figure above right.

NOTE: Lubrication of knurls of ribbed neck bolts is recommended. **DO NOT oil threaded portion of bolt.**

8. Secure side bracket fasteners with 1/2" lock washer and nut. Tighten ribbed neck bolts to 75 lb. ft..
9. The side brackets and cross angles are loosely installed. The cross angles need to be centered on the vehicle. This is done by lining up the center hole in each cross angle with the center corrugation in the truck bed. After proper alignment tighten the 1/2-13 fasteners to 75 LB.-FT.

IN-TRUCK BED GOOSENECK PLATFORM INSTALLATION INSTRUCTIONS:

10. With the cross angles and side brackets properly aligned and tightened, from under the truck, use the holes in the cross angles as a guide to drill six (6) 5/8" diameter holes for the carriage bolts and four (4) 3/4" diameter holes for the U-bolts through the truck bed. Not all holes will be able to be drilled from under the truck, but will be done later from inside the bed.
WARNING do not drill through outermost square holes in cross member.
11. Align the holes on the template (provided with the gooseneck hitch) with the holes previously drilled through the bed. Be sure that the template is properly oriented toward the front of the truck. Center punch the holes that will be used to cut the opening in the bed. If the truck is equipped with a bedliner, a section of the bedliner must be cut out so the gooseneck platform can contact the bed corrugations.
12. Drill 1/4" pilot holes (size will depend on width of blade in saber saw).
13. Cut out truck bed. File the edges as needed.

TEMPLATE P/N 5978 FOR USE WITH 6300 HEAD
 TEMPLATE P/N 8316 FOR USE WITH 8311 HEAD
 TEMPLATE P/N 100134 FOR USE WITH 8339 HEAD

A DURABLE AND REUSABLE STAINLESS STEEL TEMPLATE
 P/N 6467 IS ALSO AVAILABLE FOR USE WITH 6300 HEAD.
 A TIME SAVER FOR CUTTING BED LINER AND BED.

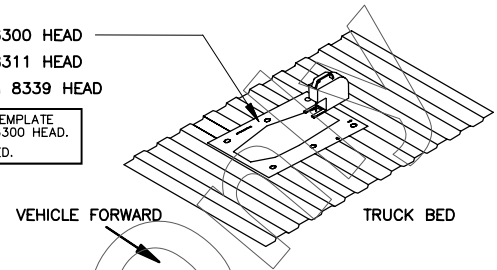

14. Install platform into opening.
15. Use the installed platform as a guide to drill 5/8" diameter holes that could not be drilled from below the vehicle.

WARNING The fuel tank and/or other vehicle components are located below some of the holes. A wood or metal shield must be placed between the frame and the fuel tank to prevent puncturing the fuel tank when the drill breaks through the bed.

16. Before installing 5/8" carriage bolts through the platform, U-block shims (P/N 5994 - Green) must be placed between the platform and the bed and between the cross angles and the bottom of the bed. If the vehicle still has a gap between the shims and the top of the cross angles (described in Step 12), add 3/16" x 2" x 1" shims (P/N 5971 - Gold) between the across angles and the bottom of the bed. These shims are necessary to prevent the bed corrugations from collapsing when the bolts are tightened.

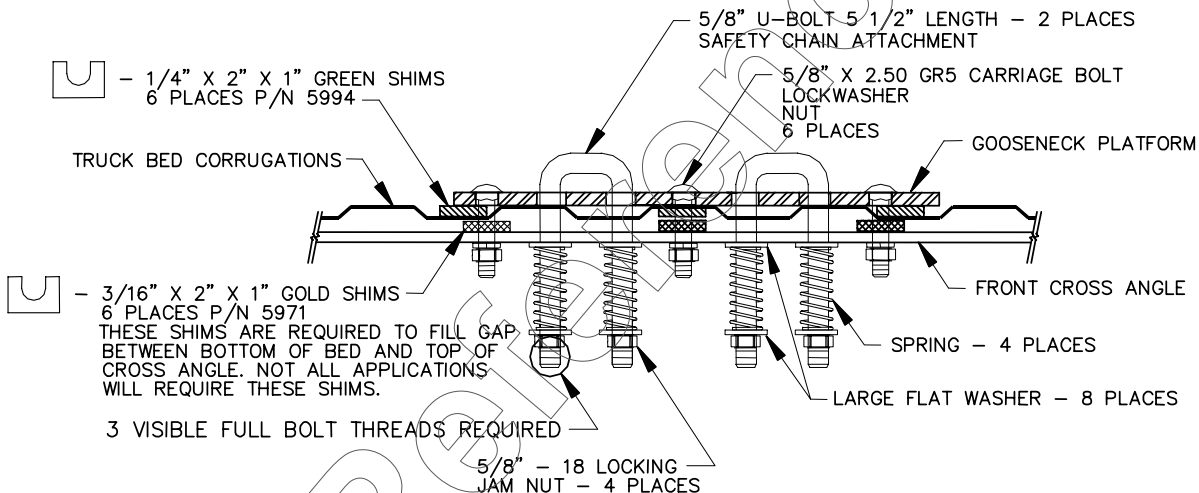

17. Install 5/8" x 2.50" GR5 carriage bolts through the platform, shims and cross angles. Secure with lock washers and nuts. Torque nuts to 150 LB.-FT.
18. Install the 2 U-bolts through the platform and from under the truck install large flat washer over the U-bolt followed by a spring, another large flat washer and secure with a thin 5/8" jam nut. Repeat for the other legs of the U-bolts. The 5/8" jam nuts are to be tightened until 3 threads are visible past the bottom of the jam nut.

6300 REMOV-A-BALL® GOOSENECK BALL INSTALLATION AND OPERATION

19. After installation, with a finger in the Z-slot raise the handle pulling it rearward and sliding it toward the side of the truck. This will allow the hitch ball to be installed into the tube. Orient the through hole in the ball so it lines up with the sliding pin. Move the handle toward the ball and then push it forward in the Z-slot to lock the handle into a closed position.

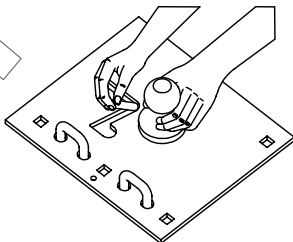

A durable hitch ball storage bag P/N 6352 is available to store greasy ball when not in use.

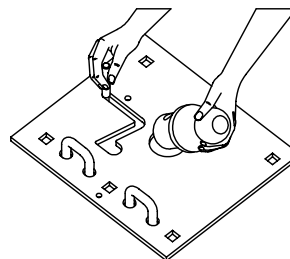

20. Cover the slot with the magnetic cover provided. This cover will keep road mud and debris out of the bed and away from your cargo.

8311 GOOSENECK BALL INSTALLATION AND OPERATION

21. Install ball and torque 3/4" bolt to 100 LB.-FT.



8339 FOLDING BALL GOOSENECK OPERATION

22. The ball assembly offers several features with the user in mind.
- Easily accessible lift ring (figure B).
 - Two spring loaded safety chain mounts. (figure E).
 - Easily accessible grease zerk (figure A).
 - Ball detent lock backup to provide double coverage in preventing ball cover from opening unintentionally.
 - Spring loaded folding mechanisms to assist actuation and prevent rattle.
 - Chrome plated decorative ball.
23. To raise ball in upright position, follow these procedures:
24. Grasp lift ring and raise cover until the spring holds the cover open. Grasp ball and rock it to its vertical position. See figures A-D.
25. Lower lift ring and cover such that it locks ball in upright position. See figure E.
26. Lift spring loaded safety chain U-bolts to attach safety chain.
27. To lower ball into horizontal position, repeat steps 24 then 25.

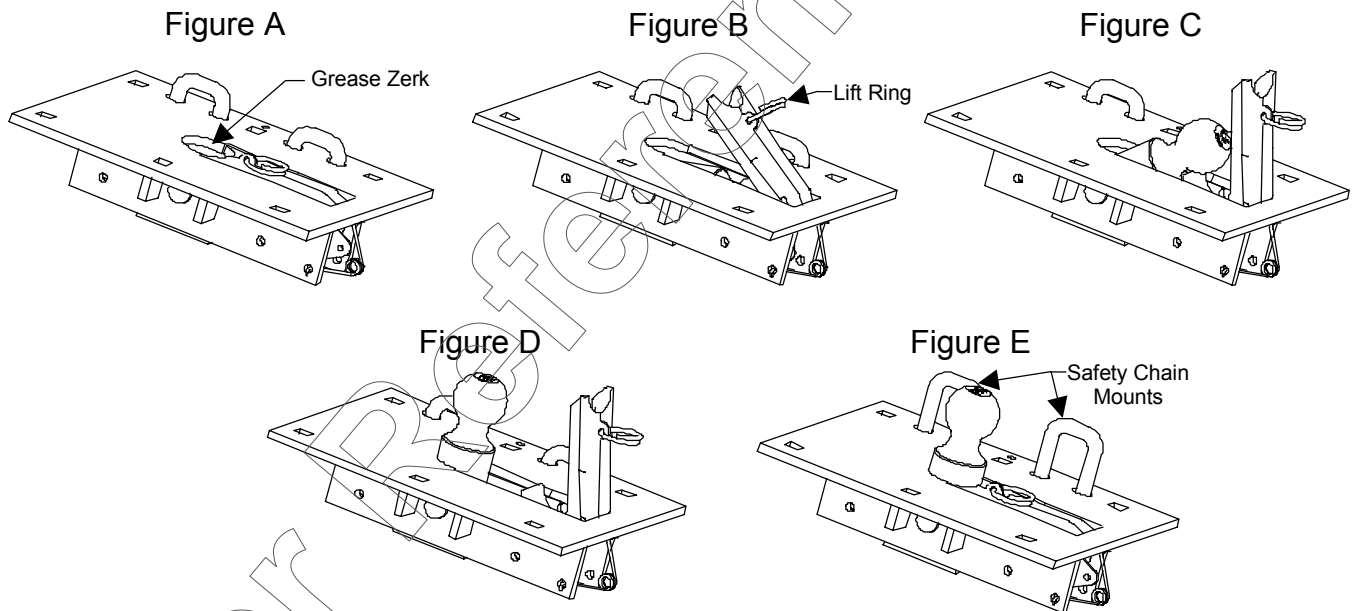
**8339 FOLDING BALL GOOSENECK MAINTENANCE**

- Keep ball envelope and pivoting mechanism free from dirt and debris.
- Lube ball cover pivot monthly with light weight oil or equivalent.
- Grease ball pivot at grease zerk monthly (See figure A)
- Lube ball detent regularly with light weight oil. Keep free from dirt and debris.
- Retorque all hardware monthly.

8315 GOOSENECK BALL INSTALLATION AND OPERATION

28. Locate the ball center per Figure F from underneath vehicle. Drill from underneath the vehicle through the bed with a 1/4" drill bit.
29. From the top of the bed drill through the bed with a 3-1/2" hole saw.

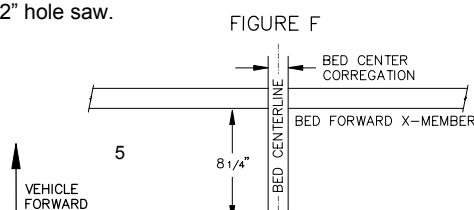

30. Loosely assemble the head, crossmember rails and side brackets off the vehicle as shown in Figure G.
NOTE: Ball bore MUST be preassembled closer to rear rail (see top view of completed assembly below).

FIGURE G

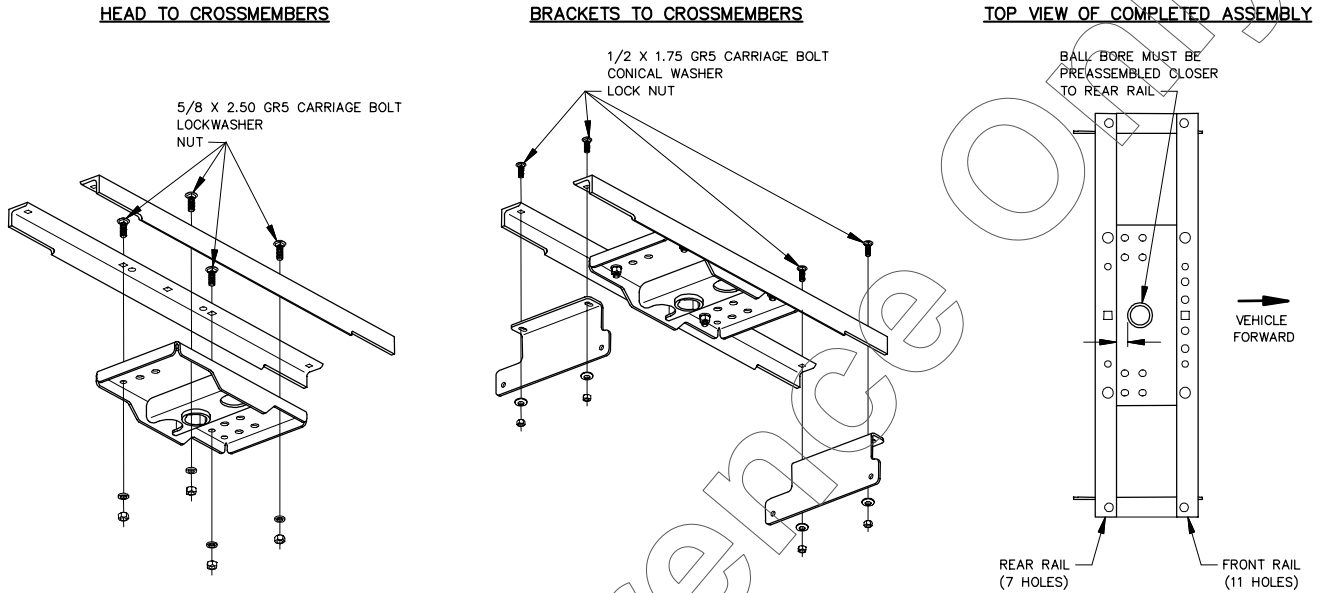
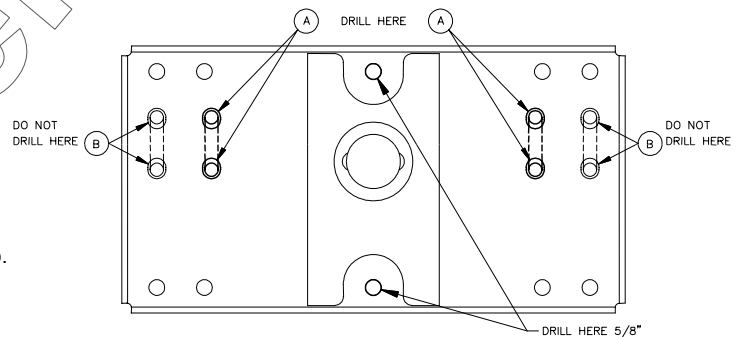
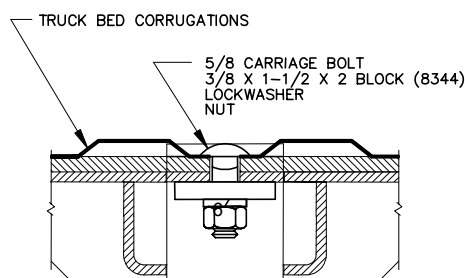

FIGURE H



31. Torque the head to rail 5/8" x 2-1/2" carriage bolts to 150 ft. lb.
 32. Remove the side brackets from the rail and head assembly.
 33. Loosen the truck bed attaching fasteners on the drivers side of the truck bed and remove the bed attaching fasteners on the passengers side of the truck bed.
 34. Tilt the truck bed and slide the head and rail assembly between the frame and bed.
 35. Align the head assembly and the drilled hole in the bed and lower the bed back onto the frame.
 36. Follow bracket installation steps 6 through 9 on page 2.
 37. Using the installed platform as a guide, from under the vehicle bed, drill two (2) 5/8" diameter holes for the center attachments as shown in Figure H above.
 38. Install 5/8" carriage bolts, block, lock washer and nut per Figure J. Torque to 150 lb.ft.

FIGURE D



- 39. Using the installed platform as a guide, from under the vehicle bed, drill four (4) 3/4" diameter holes for the chain loops as shown in Figure H above. **Warning: Do Not Drill the B Hole Pattern.**
- 40. Follow chain loop installation step 18 on page 3.

UNDERBED GOOSENECK BALL INSTALLATION AND OPERATION

- 41. After installation, loosen the hitch ball screw fully from the top of the ball. Insert the ball into the platform with the arrows on the head of the ball pointing to the sides of the vehicle.
- 42. Tighten the screw down fully to secure the ball.

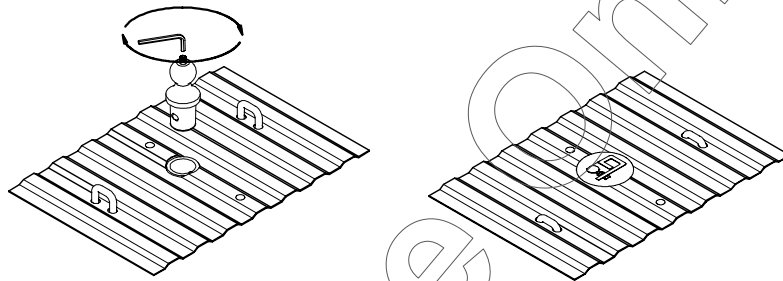

UNDERBED GOOSENECK MAINTENANCE

- Keep assembly free of dirt and debris.
 - Lubricate hitch ball monthly or as needed with heavy grease.
 - Lubricate ball tube with heavy grease when ball is installed and/or removed.
 - Check bolt torque monthly.
 - Check equipment before towing for worn or damaged parts.
- REPLACE WORN OR DAMAGED PARTS IMMEDIATELY.

UNDERBED GOOSENECK BALL MAINTENANCE

- Store ball and wrench in bag provided when not towing.
 - If internal ball mechanism begins to stick or bind, disassemble ball, clean and grease all internal components with lithium grease.
 - Always make sure the two metal prevailing torque nuts are used to retain the ball plunger.
- REPLACE WORN OR DAMAGED PARTS IMMEDIATELY.

- 1 BALL GOOSENECK
- 2 O-RING
- 3 BALL BEARING
- 4 SCREW SOCKET HEAD CAP
- 5 PLUNGER
- 6 WASHER 1/4 NYLON
- 7 LOCKNUT FLANGED 1/4-20
- 8 CAP PLASTIC

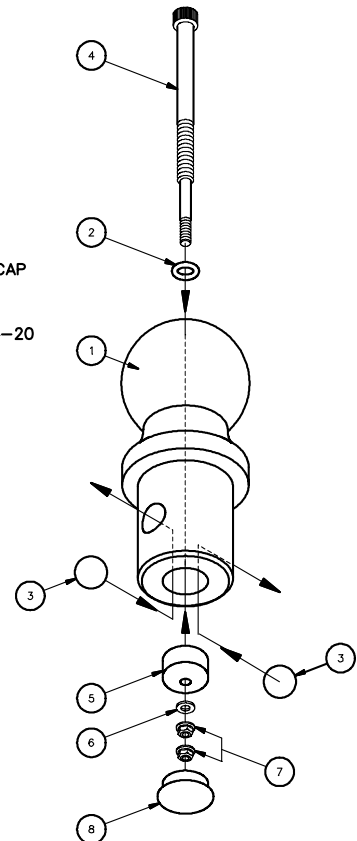

AFTER SYSTEM INSTALLATION AND BEFORE TOWING:

- 43. Connect trailer to the tow vehicle following coupler manufacturer's operating instructions.
- 44. The coupler must be adjusted to provide about six inches (6") of clearance between the bottom of the trailer nose and the top of the pickup bed sides.
- 45. Slowly back the trailer to a jackknifed position to the tow vehicle while checking to see there is adequate clearance between the gooseneck trailer and the rear of the vehicle. Also check to see if there is adequate clearance between the forward corners of the gooseneck trailer and the cab of the truck. Slowly jackknife the truck and trailer in the opposite direction and check the clearances to the end of the truck and the cab.

GOOSENECK HITCH SYSTEM

IMPORTANT INFORMATION ON TOWING

TOWING EQUIPMENT OWNERS: make sure all operators of your equipment read and understand this information before towing. Save for reference. This will help you properly use and maintain your towing equipment. Refer to owner's manuals for your tow vehicle, trailer and other parts of your towing system. Learn the capabilities and limitations of each part. **GROSS TRAILER WEIGHT** and **VERTICAL LOAD** are the two most important items to consider. **THESE WEIGHTS MUST NEVER EXCEED THE LOWEST RATING OF ANY PART OF YOUR TOWING SYSTEM.** **GROSS TRAILER WEIGHT** is the weight of the trailer plus cargo. Measure **GROSS TRAILER WEIGHT** by putting the fully loaded trailer on a vehicle scale. **VERTICAL LOAD** is the downward force exerted on the ball by the trailer coupler. Use a vehicle scale to measure **VERTICAL LOAD** with the fully loaded trailer on a level surface and the coupler at normal towing height.

TRAILER COUPLERS

The coupler should be smooth, clean and lightly lubricated. Adjust per coupler manufacturer's instructions.

SAFETY CHAINS

Connect safety chains properly **EVERY TIME YOU TOW**. Attach securely though the U-bolts provided so they can not bounce loose. Leave only enough slack to permit full turning. Too much slack may prevent chains from maintaining control if other connections separate.

TRAILER LIGHTS, TURN SIGNALS, ELECTRIC AND BREAKAWAY SWITCH CONNECTIONS

Make these safety-critical connections **EVERY TIME YOU TOW**, no matter how short the trip. Check operation, including electric brake manual control, before getting on the road.

OTHER USEFUL EQUIPMENT

AIR SPRINGS, AIRSHOCKS, or HELPER SPRINGS are useful for some applications. A TRANSMISSION COOLER may be necessary for heavy towing. Many states require TOWING MIRRORS on both sides.

TIRE INFLATION

Check often. Follow tow vehicle and trailer manufacturer's recommendations.

CHECK YOUR EQUIPMENT/REPLACE WORN PARTS

Check ball, coupler, chains, and all other connections **EVERY TIME YOU TOW**. Re-check at fuel and rest stops.

NO PASSENGERS IN TRAILER!

Never allow people in the trailer while towing, under any circumstances.

TRAILER LOADING

Place heavy objects on the floor ahead of the axle. Balance the load side-to-side. Secure it to prevent shifting. **NEVER** load the trailer rear heavy. **LOAD THE TRAILER HEAVIER IN THE FRONT, BUT NOT GREATER THAN TONGUE WEIGHT RATING OF THE HITCH.**

DRIVING

The additional weight of a trailer affects acceleration, braking and handling. Allow extra time for passing, stopping, and changing lanes. A gooseneck trailer requires a large turning radius as the trailer tracks to the inside of turns. Severe bumps can damage your towing vehicle, hitch and trailer. Drive slowly on rough roads. **STOP AND MAKE A THOROUGH INSPECTION IF ANY PART OF YOUR TOWING SYSTEM STRIKES THE ROAD. CORRECT ANY PROBLEMS BEFORE RESUMING TRAVEL.**

WARNING

DO NOT MODIFY. INSTALL ONLY ON SPECIFIED VEHICLE IN GOOD CONDITION. Do not tow one trailer behind another, which may cause loss of control. Failure to heed warnings and follow instructions may result in serious personal injury or death, vehicle crash, and/or property damage.