

INSTALLATION INSTRUCTIONS

READ THOROUGHLY BEFORE BEGINNING

6380 RAIL KIT - Chevrolet Silverado/GMC Sierra with 6' Beds for use with Draw-Tite Gooseneck Hitch - Part Number 6300, 8311, 8315 & 8339

NOTE: 1999 Chevrolet C/K and GMC Sierra Classic (Old Body Style) require Draw-Tite Rail Kit 6350 for 8' bed.

IMPORTANT!

This product is intended for installation on Chevrolet Silverado/GMC Sierra 6' Bed Pickup Truck with Draw-Tite Gooseneck Hitch Part Numbers 6300, 8311, 8315 & 8339. This installation instruction describes the installation of the Draw-Tite Rail Kit 6380 and Gooseneck Hitch 6300, 8311, 8315 & 8339. Give this installation instruction to vehicle owner after installation is complete.

**-THE MAXIMUM RATING-
DO NOT EXCEED VEHICLE MANUFACTURER'S RATING FOR 5th WHEEL TOWING**

TOOLS REQUIRED:

- Hand drill
- Drill bits - 1/4, 17/32, 9/16, 5/8, 3/4
- Sockets and wrenches - M10, M13, M18, 3/4, 13/16, 7/8, 15/16, 1-1/8 and Torx T-25
- Center punch
- Torque wrench
- Saber saw
- Files - round & flat
- Hammer
- Hole saw - 3-1/2"

PARTS LIST:

- Tube crossmember P/N 6373
- Angle crossmember P/N 6374
- Driver's side bracket P/N 6382
- Passenger side bracket P/N 6383
- Fastener Kit P/N F6380

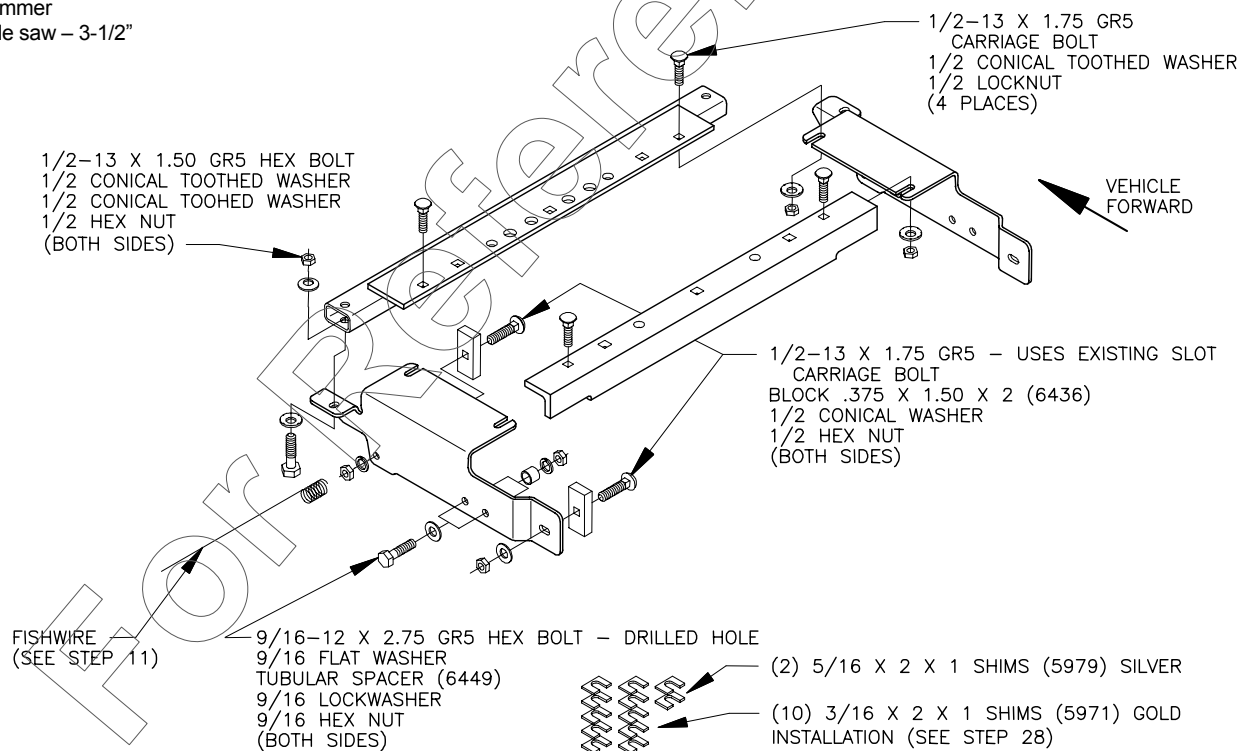

NOTE: CHECK HITCH FREQUENTLY, MAKING SURE ALL FASTENERS ARE PROPERLY TIGHTENED. A HITCH OR BALL WHICH HAS BEEN DAMAGED SHOULD BE REMOVED AND REPLACED. OBSERVE SAFETY PRECAUTIONS WHEN WORKING BENEATH A VEHICLE AND WEAR EYE PROTECTION. FOLLOW VEHICLE MAKER'S SPECIFICATIONS FOR MAXIMUM TRAILER WEIGHT. DO NOT CUT ACCESS OR ATTACHMENT HOLES WITH A TORCH.

INSTALLATION INSTRUCTIONS:

⚠ WARNING Fuel lines, brake lines and electrical wires are located along the inside of the driver's side frame rail. The hanger(s) for lines may need to be loosened and/or moved during the installation. Be careful not to kink, puncture or damage these lines. After installation, do not allow these lines to rub against any of the fasteners, side brackets or crossmembers. Examine the back side of the frame before drilling to be sure there are no lines, wires or fuel tank that can be damaged when drill breaks through the frame. If a fuel tank is on the back side, a shield of wood or metal must be used to protect the fuel tank from being punctured.

TRAILER/VEHICLE CLEARANCE DETERMINATION:

Before beginning installation, measure your Gooseneck trailer to determine that your trailer will have adequate clearance to your tow vehicle. Measure from the center of the coupler to the nearest vertical component on your trailer that could swing during a turn and contact your tow vehicle. Record this dimension (A) _____. Measure from the center of the coupler diagonally to the forward corner of the trailer nose, this part of the trailer could contact your cab during a turn. Record this dimension (B) _____.

If (A) measures less than (A) listed on the chart below, trailer will contact tow vehicle and hitch should not be installed.
 If (B) measures more than (B) listed on the chart below, trailer will contact tow vehicle and hitch should not be installed.

6' Bed (A) = 57"
 (B) = 55"

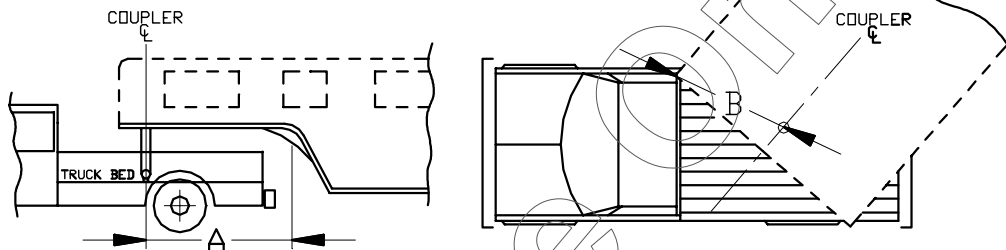

NOTE: The measurements above are guidelines. If your measurements are close to these numbers re-check clearances. If vehicle and/or trailer has any added bed vicinity accessories (i.e. fairings, airdams, ground effects, bed rails, etc.). Added dimensioning and clearance checks have to be made.

HEAT SHIELD REMOVAL

1. Lower spare tire – tools are located behind passenger seat. Vehicle key is required to unlock the spare tire access hole in the bumper.
2. Removal of the heat shield is difficult and requires a combination of box and open end wrenches and sockets. Raising the bed of the truck is recommended.
3. To raise the bed loosen eight (8) [4 per side] bed bolts using M18 socket. Two (2) bolts at the end of the frame are accessed through clearance holes in the bottom flange of the frame. The forward two (2) bolts are attached to the bed through brackets mounted to the side of the frame. With bolts loosened, raise the bed up off the truck frame about one inch (1”).
4. The heat shield is in two pieces on some vehicles. The rear section of the heat shield needs to be removed. An M10 socket is required to remove eight (8) screw and washer assemblies. With the shield loose, slide it toward the center of the truck then forward until the rear edge of the shield clears the forward spare tire crossmember support. Push the rear edge of the shield down and slide the heat shield rearward and out. Set shield aside for trimming (see page 5) along with screws for reinstallation later.

6300, 8311 & 8339 INSTALLATION
(for 8315 Installation go to page 7)

FORWARD FABRICATED TUBE CROSSMEMBER INSTALLATION

5. Install 1/2-13 x 1-3/4 GR 5 carriage bolts in the square holes in the crossmember. Slide the crossmember into position over the top of the frame rails with the holes in the flat bar pointing toward the rear of the vehicle.

REAR ANGLE CROSSMEMBER INSTALLATION

6. Install 1/2-13 x 1-3/4 GR 5 carriage bolts in the square holes in the angle. Orient the three (3) holes in the angle facing toward the front of the vehicle.

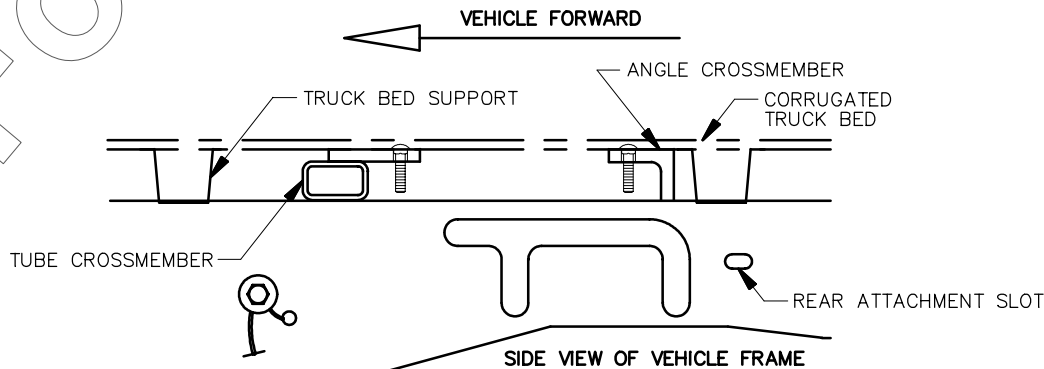

SIDE BRACKET INSTALLATION

7. The driver's side bracket is the first to be installed.
8. Raise the side bracket against the outside of the frame and slide the top leg of the side bracket under the cross angle and tube/crossmember so that the carriage bolts in the crossmembers engage the slots in the side bracket.
9. Place a conical toothed washer and locknut on the ½-13 x 1-3/4 GR 5 carriage bolts that are hanging through the crossmembers and slots in the top leg of the side bracket and loosely tighten.

Rear Attachment – uses existing slot/hole

10. For 2001 and later heavy duty 2500 and 3500 vehicles relocate the wiring harness clip and enlarge existing hole, from inside the frame insert ½-13 x 1-3/4 GR 5 carriage bolt and thick block 3/8 x 1-1/2 x 2 through slot in frame and side bracket and secure loosely with lock washer and nut. See diagram at bottom of page 2.

Forward Attachment – uses existing slot

11. Insert the coiled end of the fishwire (provided loose in carton) through the hole in side bracket and frame. Screw a ½-13 x 1-3/4 GR 5 carriage bolt with ¼ x 1 x 2 block onto the coiled end of the fishwire and pull the assembly out through the boxed section of frame and side bracket. Carefully unthread the bolt from the fishwire and secure loosely with lock washer and nut.

Side Bracket to Tube Crossmember – verticle attachment

12. Insert ½-13 x 1-1/2 GR5 hex bolt through conical toothed washer, side bracket and tube crossmember. Secure loosely with conical washer and nut.

13. Repeat steps 8 through 12 for passenger's side bracket.

Position Crossmembers and Side Brackets

14. Move the side brackets, as needed, so that the aft center hole in the side brackets is ½ inch rearward of the forward corner of the bed support. This will locate the center hole in the side brackets between the frame jounce bracket which is located inside the frame rails. This alignment is critical to allow proper clearance for a socket to fit over the nuts when tightening.

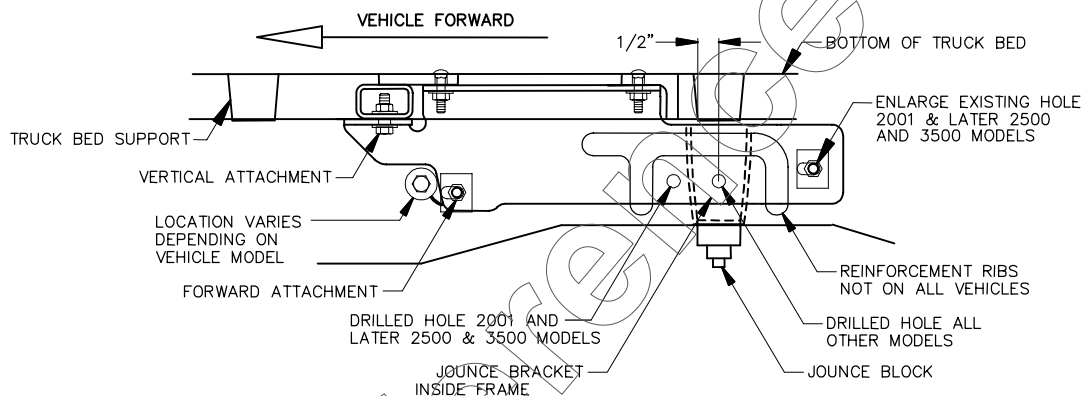
**Center Attachment – hole must be drilled**

15. Using the proper hole as a guide drill a 9/16 diameter hole through the frame. While holding tubular spacer between frame and side bracket, insert 9/16 hex bolt with washer through side bracket, tubular spacer and frame. Secure loosely with lock washer and nut.

⚠ WARNING Be careful while drilling. A wood or metal shield must be placed between the frame and vehicle components to prevent damage when the drill breaks through the frame.

16. Repeat the forward and center attachments on the passenger's side.
17. With the side brackets, crossmembers and all fasteners loosely installed, the crossmembers need to be centered on the vehicle. This is done by lining up the center hole in each crossmember with the center corrugation in the truck bed. After proper alignment, torque the 9/16-12 GR5 hex bolts in the center attachment to 110 LB-FT. Torque all the ½-13 GR5 fasteners to 75 LB-FT.

Be sure to reattach any fuel lines, brake lines, electrical wires or cables. Be certain that they cannot rub against the tightened fasteners, side brackets or crossmembers.

18. Lower truck bed onto frame and using M18 socket, torque the eight (8) bed bolts to 75 LB-FT.

IN-TRUCK BED GOOSENECK PLATFORM INSTALLATION INSTRUCTIONS:

19. With crossmembers and side brackets properly aligned and all fasteners including bed bolts tightened, use the holes in the crossmembers to drill 5/8 and 3/4 diameter holes up through the truck bed. Not all holes can be drilled from under the truck, but will be done later from inside the bed. **WARNING, DO NOT DRILL THROUGH OUTERMOST SQUARE HOLES IN CROSSMEMBERS.**
20. Align the holes on the template (provided with the gooseneck hitch) with the holes previously drilled through the bed. Be sure that the template is properly oriented toward the front of the truck. If the truck is equipped with a bedliner, a section of the bedliner must be cut out so the gooseneck platform can contact the bed corrugations. Center punch the holes that will be used to cut the opening in the bed.
21. Drill 1/4 pilot holes (size will depend on width of blade in saber saw).
22. Cut out truck bed. File the edges as needed.

TEMPLATE P/N 5978 FOR USE WITH 6300 HEAD
 TEMPLATE P/N 8316 FOR USE WITH 8311 HEAD
 TEMPLATE P/N 100134 FOR USE WITH 8339 HEAD

A DURABLE AND REUSABLE STAINLESS STEEL TEMPLATE
 P/N 6467 IS ALSO AVAILABLE FOR USE WITH 6300 HEAD.
 A TIME SAVER FOR CUTTING BED LINER AND BED.

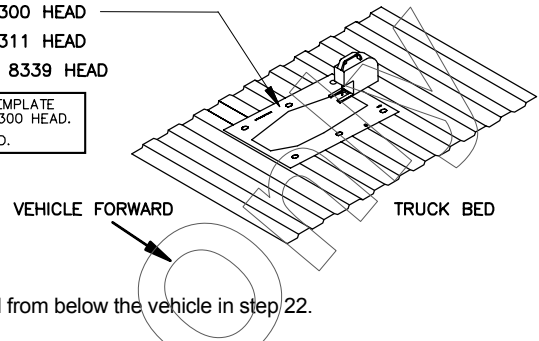

23. Install platform into opening.
24. Use the installed platform as a guide to drill 5/8 diameter holes that could not be drilled from below the vehicle in step 22.

⚠ WARNING The fuel tank and/or other vehicle components are located below some of the holes. A wood or metal shield must be placed between the frame and the fuel tank to prevent puncturing the fuel tank when the drill breaks through the bed.

25. Before installing 5/8 carriage bolts through the platform, U-block shims must be placed between the platform and the bed and between the crossmember and the bottom of the bed. These shims are necessary to prevent the bed corrugations from collapsing when the bolts are tightened. See diagram below.

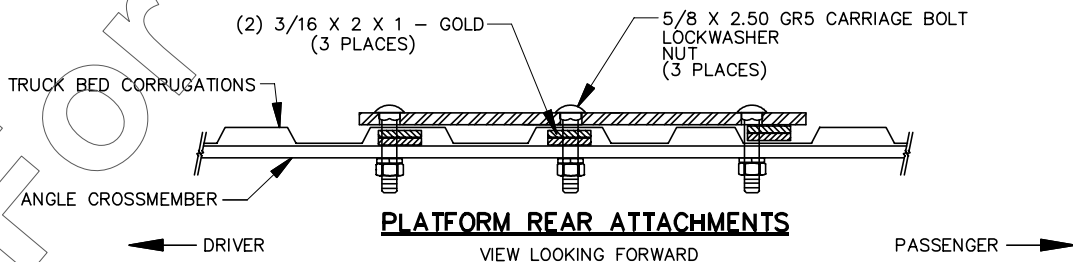
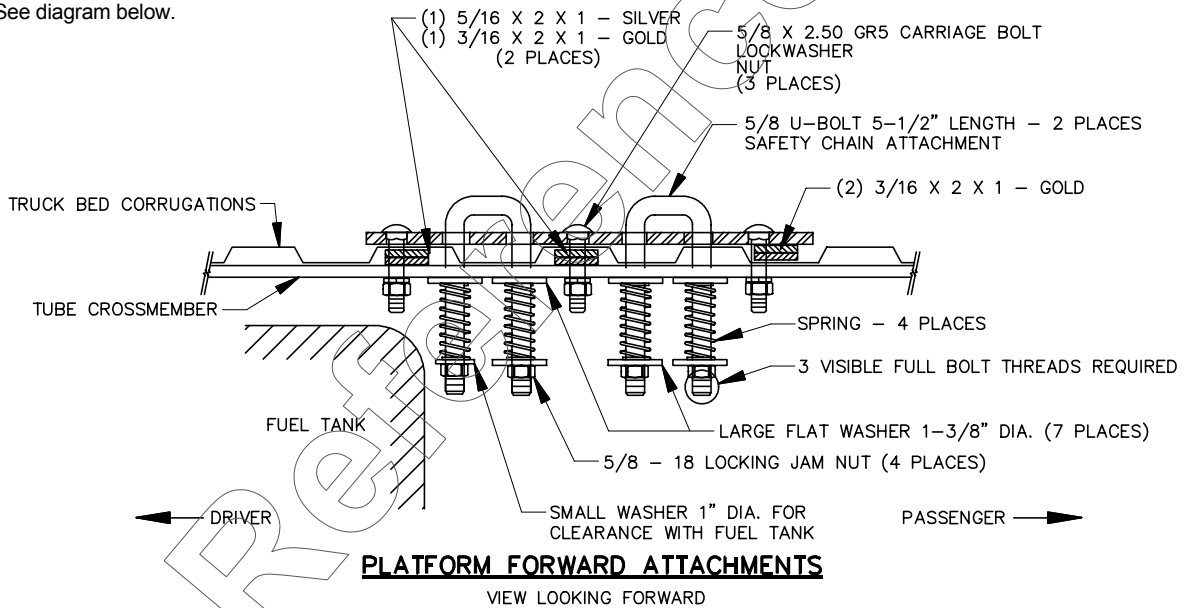

26. Install 5/8 x 2-1/2 GR5 carriage bolts through platform, shims and crossmembers. Secure with lock washer and nut. Torque nuts to 150 LB-FT.
27. Install two (2) U-bolts through the platform. To prevent contact with the fuel tank, the leg of the U-bolt hanging closest to the fuel tank requires a large flat washer, 1-3/8 diameter, followed by a spring, small flat washer one inch (1") diameter and 5/8 jam nut. On the other U-bolt legs, the spring is sandwiched between large 1-3/8 diameter flat washers top and bottom and secured with jam nuts. See diagram above.

HEAT SHIELD TRIMMING

28. Trim rear heat shield per sketch.

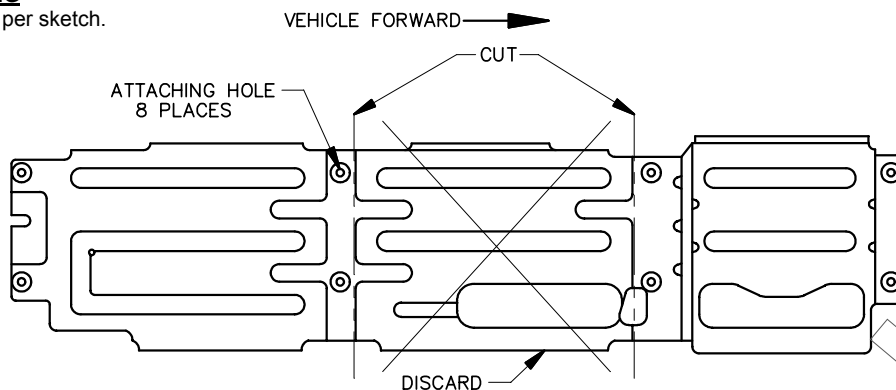

29. Reinstall heat shield using screws removed previously (see page 2).

30. Reinstall spare tire.

6300 REMOV-A-BALL® GOOSENECK BALL INSTALLATION AND OPERATION

31. After installation, with a finger in the Z-slot raise the handle pulling it rearward and sliding it toward the side of the truck. This will allow the hitch ball to be installed into the tube. Orient the through hole in the ball so it lines up with the sliding pin. Move the handle toward the ball and then push it forward in the Z-slot to lock the handle into a closed position.

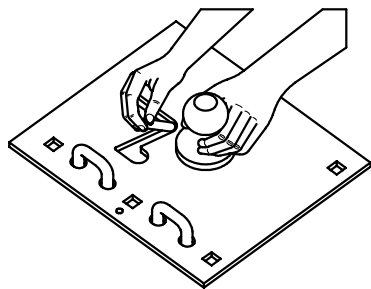

A durable hitch ball storage bag P/N 6352 is available to store greasy ball when not in use.

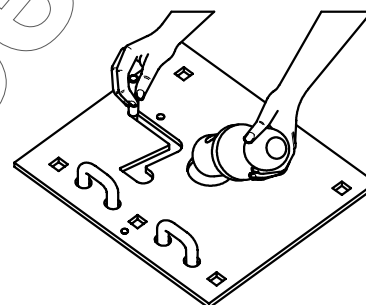

32. Cover the slot with the magnetic cover provided. This cover will keep road mud and debris out of the bed and away from your cargo.

8311 GOOSENECK BALL INSTALLATION AND OPERATION

33. Install ball and torque $\frac{3}{4}$ " bolt to 100 LB.-FT.

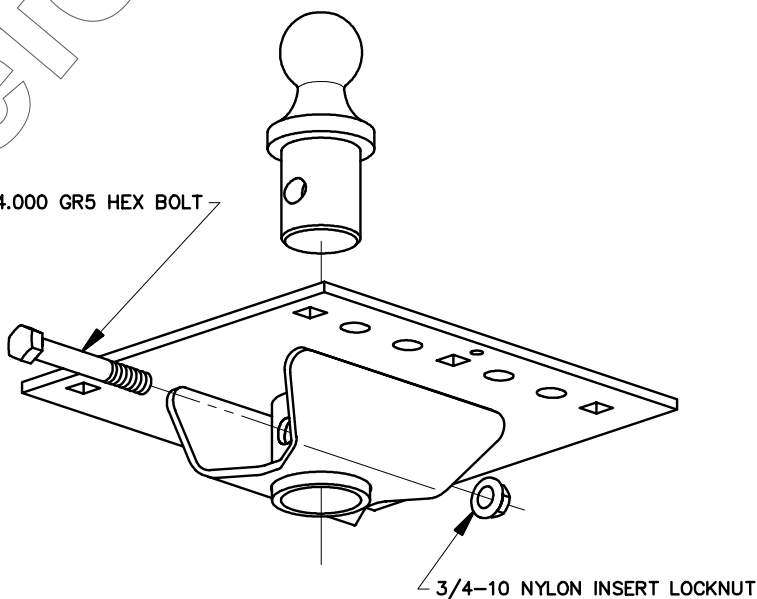

8339 FOLDING BALL GOOSENECK OPERATION

34. The ball assembly offers several features with the user in mind.

- Easily accessible lift ring (figure B).
- Two spring loaded safety chain mounts. (figure E).
- Easily accessible grease zerk (figure A).
- Ball detent lock backup to provide double coverage in preventing ball cover from opening unintentionally.
- Spring loaded folding mechanisms to assist actuation and prevent rattle.
- Chrome plated decorative ball.

35. To raise ball in upright position, follow these procedures:

36. Grasp lift ring and raise cover until the spring holds the cover open. Grasp ball and rock it to its vertical position. See figures A-D.

37. Lower lift ring and cover such that it locks ball in upright position. See figure E.

38. Lift spring loaded safety chain U-bolts to attach safety chain.

39. To lower ball into horizontal position, repeat steps 36 then 37.

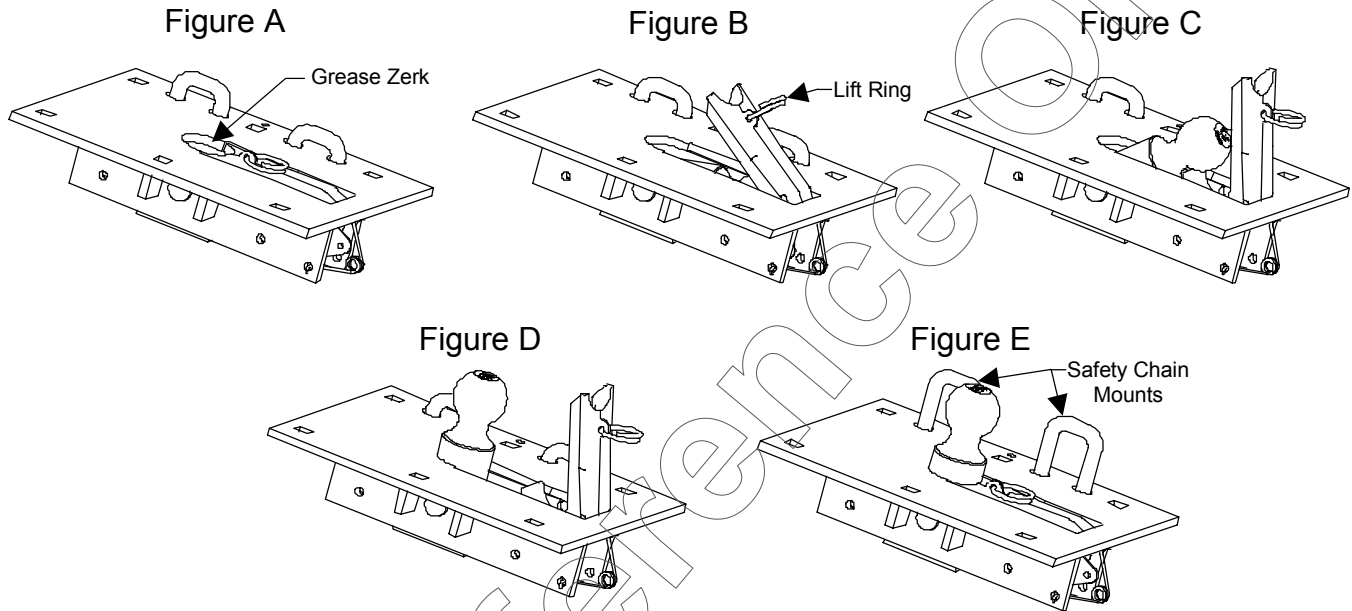
**8339 FOLDING BALL GOOSENECK MAINTENANCE**

- Keep ball envelope and pivoting mechanism free from dirt and debris.
- Lube ball cover pivot monthly with light weight oil or equivalent.
- Grease ball pivot at grease zerk monthly (See figure A)
- Lube ball detent regularly with light weight oil. Keep free from dirt and debris.
- Retorque all hardware monthly.

8315 GOOSENECK BALL INSTALLATION AND OPERATION

40. Locate the ball center per Figure F from underneath vehicle. Drill from underneath the vehicle through the bed with a 1/4" drill bit.

41. From the top of the bed drill through the bed with a 3-1/2" hole saw.

FIGURE F

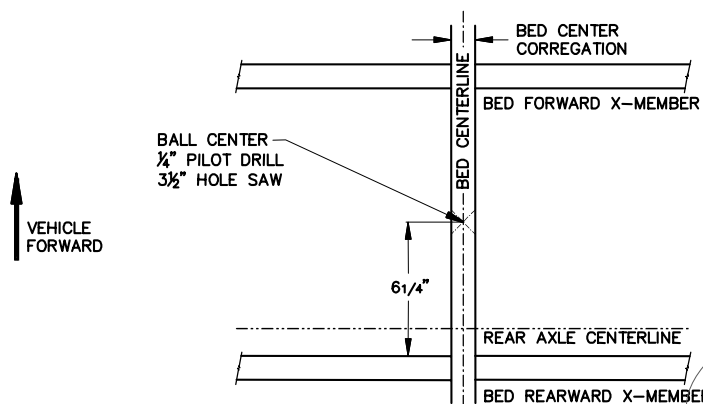

42. Loosely assemble the head, crossmember rails and side brackets off the vehicle as shown in Figure G.

NOTE: Ball bore MUST be preassembled closer to rear rail (see top view of completed assembly below).

FIGURE G

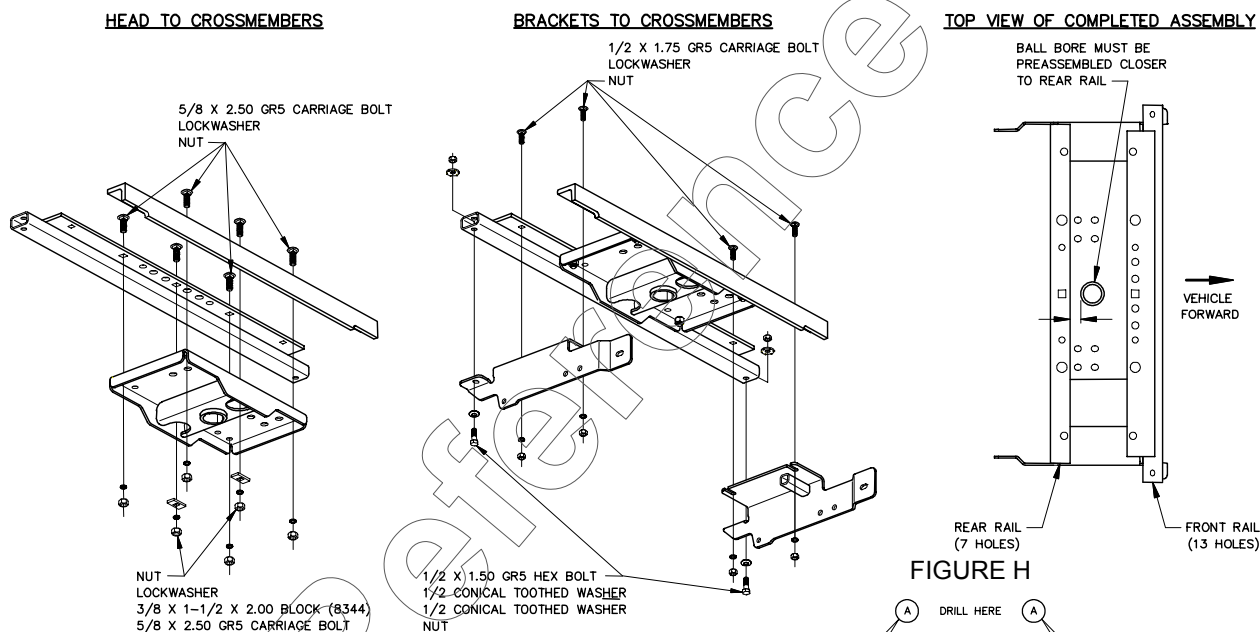
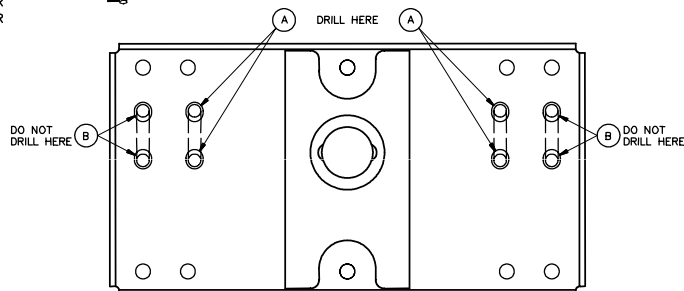

FIGURE H



43. Torque the head to rail 5/8" x 2-1/2" carriage bolts to 150 ft. lb.

44. Remove the side brackets from the rail and head assembly

45. Loosen the truck bed attaching fasteners on the drivers side of the truck bed and remove the bed attaching fasteners on the passengers side of the truck bed.

46. Tilt the truck bed and slide the head and rail assembly between the frame and bed.

47. Align the head assembly and the drilled hole in the bed and lower the bed back onto the frame.

48. Follow bracket installation steps 7 through 18 on page 3.

49. Using the installed platform as a guide, drill four (4) 3/4" diameter holes for the chain loops as shown in Figure H above.

Warning: Do Not Drill the B Hole Pattern.

50. Follow chain loop installation step 27 on page 4.

UNDERBED GOOSENECK BALL INSTALLATION AND OPERATION

51. After installation, loosen the hitch ball screw fully from the top of the ball. Insert the ball into the platform with the arrows on the head of the ball pointing to the sides of the vehicle.

52. Tighten the screw down fully to secure the ball.

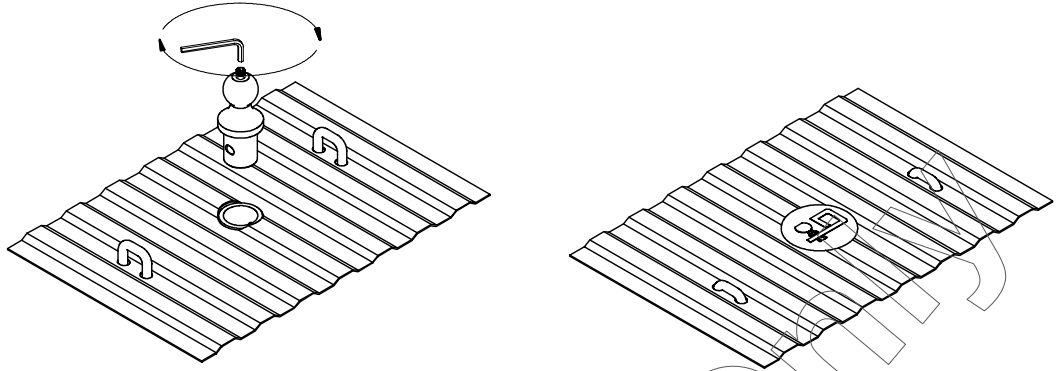

UNDERBED GOOSENECK MAINTENANCE

- Keep assembly free of dirt and debris.
 - Lubricate hitch ball monthly or as needed with heavy grease.
 - Lubricate ball tube with heavy grease when ball is installed and/or removed.
 - Check bolt torque monthly.
 - Check equipment before towing for worn or damaged parts.
- REPLACE WORN OR DAMAGED PARTS IMMEDIATELY.**

UNDERBED GOOSENECK BALL MAINTENANCE

- Store ball and wrench in bag provided when not towing.
 - If internal ball mechanism begins to stick or bind, disassemble ball, clean and grease all internal components with lithium grease.
 - Always make sure the two metal prevailing torque nuts are used to retain the ball plunger.
- REPLACE WORN OR DAMAGED PARTS IMMEDIATELY.**

- 1 BALL GOOSENECK
- 2 O-RING
- 3 BALL BEARING
- 4 SCREW SOCKET HEAD CAP
- 5 PLUNGER
- 6 WASHER 1/4 NYLON
- 7 LOCKNUT FLANGED 1/4-20
- 8 CAP PLASTIC

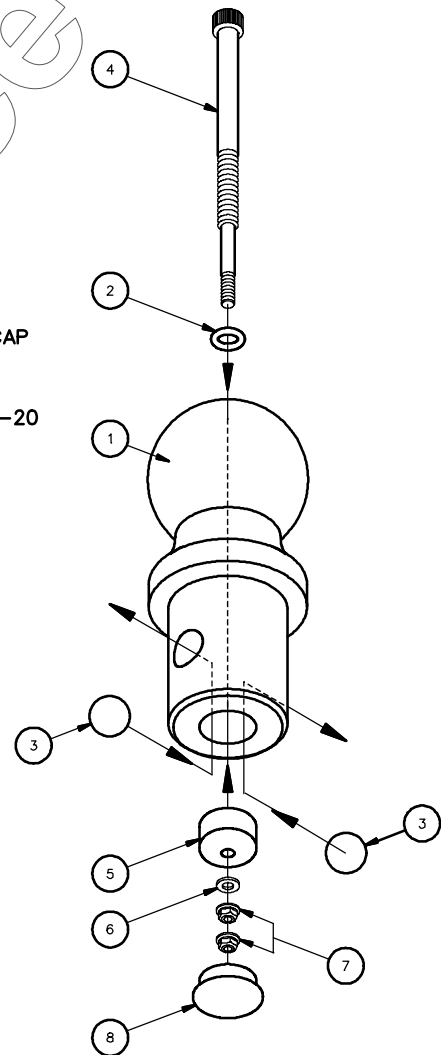

AFTER SYSTEM INSTALLATION AND BEFORE TOWING:

53. Connect trailer to the tow vehicle following coupler manufacturer's operating instructions.
54. The coupler must be adjusted to provide about six inches (6") of clearance between the bottom of the trailer nose and the top of the pickup bed sides.
55. Slowly back the trailer to a jackknifed position to the tow vehicle while checking to see there is adequate clearance between the gooseneck trailer and the rear of the vehicle. Also check to see if there is adequate clearance between the forward corners of the gooseneck trailer and the cab of the truck. Slowly jackknife the truck and trailer in the opposite direction and check the clearances to the end of the truck and the cab.

GOOSENECK HITCH SYSTEM

IMPORTANT INFORMATION ON TOWING

TOWING EQUIPMENT OWNERS: make sure all operators of your equipment read and understand this information before towing. Save for reference. This will help you properly use and maintain your towing equipment. Refer to owner's manuals for your tow vehicle, trailer and other parts of your towing system. Learn the capabilities and limitations of each part. GROSS TRAILER WEIGHT and VERTICAL LOAD are the two most important items to consider. **THESE WEIGHTS MUST NEVER EXCEED THE LOWEST RATING OF ANY PART OF YOUR TOWING SYSTEM. GROSS TRAILER WEIGHT** is the weight of the trailer plus cargo. Measure GROSS TRAILER WEIGHT by putting the fully loaded trailer on a vehicle scale. **VERTICAL LOAD** is the downward force exerted on the ball by the trailer coupler. Use a vehicle scale to measure **VERTICAL LOAD** with the fully loaded trailer on a level surface and the coupler at normal towing height.

TRAILER COUPLERS

The coupler should be smooth, clean and lightly lubricated. Adjust per coupler manufacturer's instructions.

SAFETY CHAINS

Connect safety chains properly **EVERY TIME YOU TOW**. Attach securely though the U-bolts provided so they can not bounce loose. Leave only enough slack to permit full turning. Too much slack may prevent chains from maintaining control if other connections separate.

TRAILER LIGHTS, TURN SIGNALS, ELECTRIC AND BREAKAWAY SWITCH CONNECTIONS

Make these safety-critical connections **EVERY TIME YOU TOW**, no matter how short the trip. Check operation, including electric brake manual control, before getting on the road.

OTHER USEFUL EQUIPMENT

AIR SPRINGS, AIRSHOCKS, or HELPER SPRINGS are useful for some applications. A TRANSMISSION COOLER may be necessary for heavy towing. Many states require TOWING MIRRORS on both sides.

TIRE INFLATION

Check often. Follow tow vehicle and trailer manufacturer's recommendations.

CHECK YOUR EQUIPMENT/REPLACE WORN PARTS

Check ball, coupler, chains, and all other connections **EVERY TIME YOU TOW**. Re-check at fuel and rest stops.

NO PASSENGERS IN TRAILER!

Never allow people in the trailer while towing, under any circumstances.

TRAILER LOADING

Place heavy objects on the floor ahead of the axle. Balance the load side-to-side. Secure it to prevent shifting. **NEVER** load the trailer rear heavy. **LOAD THE TRAILER HEAVIER IN THE FRONT, BUT NOT GREATER THAN TONGUE WEIGHT RATING OF THE HITCH.**

DRIVING

The additional weight of a trailer affects acceleration, braking and handling. Allow extra time for passing, stopping, and changing lanes. A gooseneck trailer requires a large turning radius as the trailer tracks to the inside of turns. Severe bumps can damage your towing vehicle, hitch and trailer. Drive slowly on rough roads. **STOP AND MAKE A THOROUGH INSPECTION IF ANY PART OF YOUR TOWING SYSTEM STRIKES THE ROAD. CORRECT ANY PROBLEMS BEFORE RESUMING TRAVEL.**

WARNING

DO NOT MODIFY. INSTALL ONLY ON SPECIFIED VEHICLE IN GOOD CONDITION. Do not tow one trailer behind another, which may cause loss of control. Failure to heed warnings and follow instructions may result in serious personal injury or death, vehicle crash, and/or property damage.