

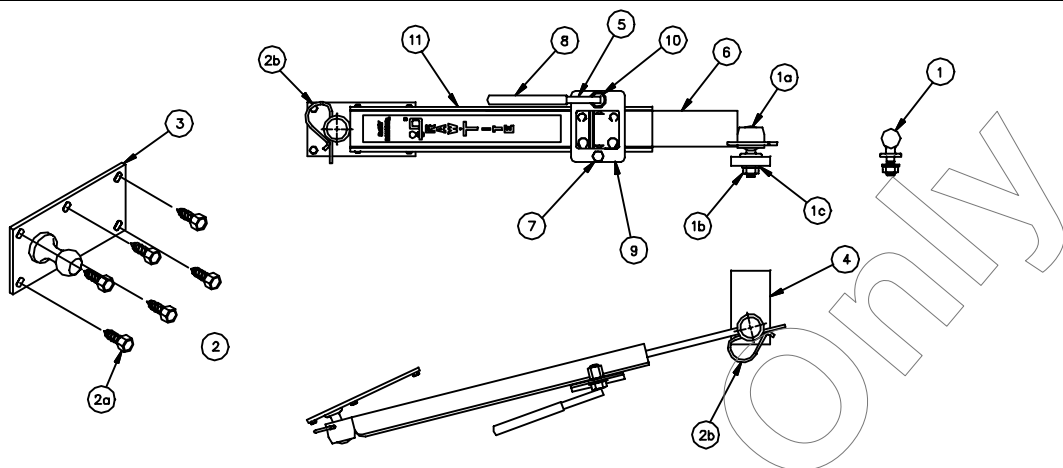

INSTALLATION INSTRUCTIONS

SWAY CONTROL

3400



REF.	PART NUMBER	QTY.	DESCRIPTION	REF.	PART NUMBER	QTY.	DESCRIPTION
1	3443	1	Ball Assembly	4	3442	1	Bar - Ball Mounting (sold separately)
1a	*	1	Ball	5	3457	1	Handle, On/Off
1b	*	1	Nut, Hex, 5/8-11	6	3422	1	Slide Bar
1c	*	1	Lock Washer	7	3406-005	1	Bolt, Tension Adjusting
2	3401	1	Fastener Kit	8	3436	1	Grip, Handle
2a	3403 **	6	Screw, Self Tapping 24-9 X 1	9	3459	1	Compression Plate Ass'y
2b	2867 **	2	Clip	10	3306	1	Washer, Hardened
3	3473	1	Ball/Plate Assembly	11	3458	1	Main Body Ass'y

* INCLUDED IN 3443 BALL ASSEMBLY

** INCLUDED IN 3401 FASTENER KIT, ALSO SOLD SEPARATELY

FIGURE 1

READ ALL INSTRUCTIONS AND CHECK PACKAGE CONTENTS

IMPORTANT

- 1. SWAY CONTROL CANNOT BE USED ON TRAILERS WITH SURGE BRAKES. DO NOT USE SWAY CONTROL ON CLASS I OR II HITCHES. USE ON CLASS III OR IV ONLY.**
- Trailer loading: Proper trailer loading is your first-line defense against dangerous instability and sway. Heavy items should be placed on the floor in front of the axle. The load should be balanced side-to-side and secured to prevent shifting. Tongue weight should be about 10-15 percent of gross trailer weight for most trailers. Too low a percentage of tongue weight can cause sway. Load the trailer heavier in front.
- The handle (5) is an on/off device. The bolt (7) below is for adjustment only.
- When towing during slippery conditions such as wet, icy, or snow-covered roads or on loose gravel, turn on/off handle (5) counterclockwise until all tension is removed from unit. Failure to do so could prevent tow vehicle and trailer from turning properly.
- Do not speed up if sway occurs. Sway increases with speed. Do not continue to operate a swaying vehicle. Check trailer loading, sway control adjustment and all other equipment until the cause of sway has been determined and corrected.
- Never paint or lubricate slide bar (6).

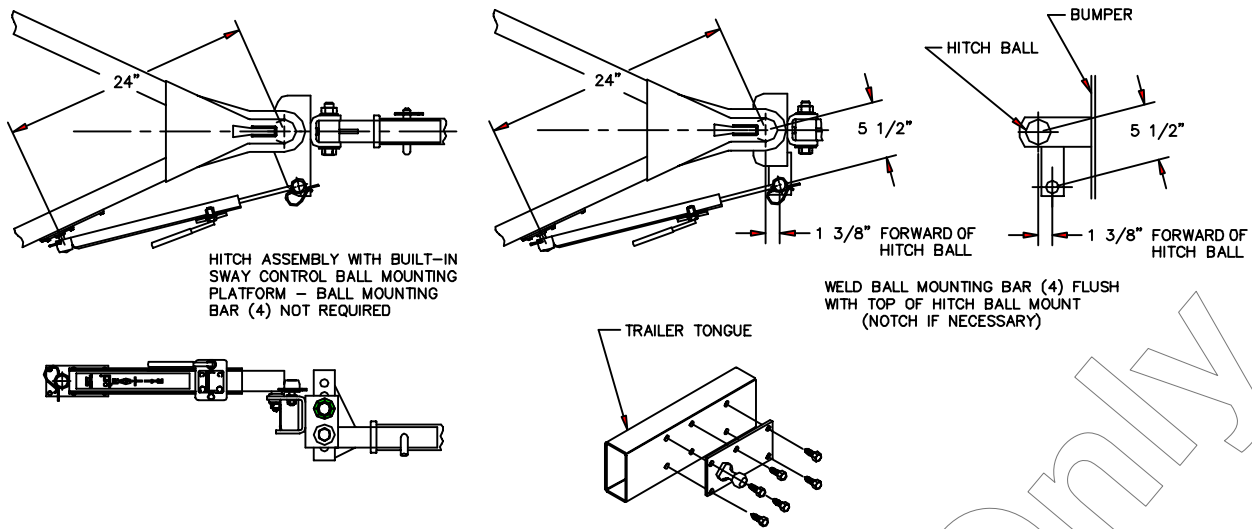

GENERAL SWAY CONTROL MOUNTING DIMENSIONS

FIGURE 2

1. INSTALLATION

Refer to Figures 1 and 2

- Connect trailer to tow vehicle. Position vehicle and trailer in a straight line on a level surface.
- Mount sway control ball (1a) using nut (1b) and lock washer (1c) to hitch as shown in Figure 2 and torque to 100 lb.-ft. If necessary notch and weld ball mounting bar (4) (sold separately) into position shown.
- Measure and mark a point on the trailer tongue 24" from the center of the hitch ball as shown in Figure 2.
- Align the center of the ball of the ball/plate assembly (3) with the mark on the trailer tongue and center punch four hole locations. Drill four holes using an 11/32 (.343) drill bit for 1/8" (.125) or thicker trailer tongue material, or a 9/32" (.281) drill bit for thinner material.
- Position the ball/plate assembly (3) over the drilled holes and drive four of the self tapping screws (2a) through the plate and into the trailer tongue. Drill the two remaining holes and install the screws.

NOTE: For left hand installation, remove slide bar (6), and reinstall upside down.

2. HOOK-UP

- Lubricate both balls with a small amount of grease, place socket of slide bar (6) over ball (1) and secure with clip (2b). Loosen handle (5) until the slide bar can be moved. Extend sway control assembly and place socket over ball on trailer, secure with other clip (2b).
- Retighten handle until it stops (handle should be in its original level position). The sway control assembly is preset at the factory with a tension suitable for most light trailers.
- On some installations, damage to the sway control may occur during extremely sharp turning maneuvers. This can be checked by slowly backing vehicle into a jackknife position while someone is watching. Do not allow slide bar to contract completely (bottom out) or bumper to contact sway control. If it looks as though contact will be made or the sway control will bottom out then the sway control must be removed before backing trailer.

3. ADJUSTMENT

- Trailer configurations and loading, road and weather conditions, towing speed, tire condition and pressure, and center of gravity of trailer all affect towing. To get maximum benefits from the sway control assembly, a series of road tests should be taken with the loaded trailer. During the first road test try the sway control at the factory preset force. On subsequent trips increase or decrease tension by turning the adjusting bolt (7) in 1/4 turn increments in the direction shown on the label until the desired control is achieved. For large trailers, it may be necessary to install a second sway control unit.
- After about 1000 miles of towing, remove the slide bar from the sway control and clean the friction surfaces with a wire brush. Repeat this cleaning procedure about every 10,000 miles.

4. UNHOOKING

- Release tension by turning on/off handle counterclockwise.
- Remove both clips (2b), remove sway control.