



# Installation, and Operating Instructions

## 2-Bike Carrier

### Part Number 6115

- WARNING:** Do not lubricate threads. Bolt failure may occur due to over tightening.
- WARNING:** Do not cut, drill, or weld to this product.
- WARNING:** This bike carrier must not be mounted behind a trailer.
- WARNING:** Do not over load carrier. See load rating label on bike carrier.

- NOTE:** All bikes need to be securely attached to the carrier.
- NOTE:** This product is intended for bicycles only.

**WEIGHT CAPACITY**  
85 lb. total bike weight

### INSTALLING THE RUBBER PADS

**IMPORTANT:** The mounting surface temperature of the bike carrier plates must be a minimum of (70°F / 21°C) for the pad adhesive to bond properly.

1. Be sure the top and bottom plates are free of dirt and debris. After the plates are clean, wipe them with the supplied alcohol pads, to aid adhesion.
2. Remove the backings from the adhesive strips on one of the rubber pads.
3. Fold the pad, bringing the long non adhesive sides together. Be sure that the bottom of the fold is the first part to contact the plate. Press the bottom of the pad firmly into the bottom of the plate. See FIG 1.
4. Slowly release the sides of the pad from the bottom to the top of the sides. The pad should not have any air gaps under the adhesive. See FIG 1.
5. Repeat for all pads.
6. After the bike rack assembly is complete, install bikes on the rack and tighten the top plate firmly. Leave for a minimum of 12 hours to allow the adhesive to bond.

### LOADING YOUR BIKES (SEE WEIGHT CAPACITY NOTE ABOVE)

1. Rest the horizontal top tube or optional mounting bar (#6145) for a lady's bike in one of the bike channels. Position the bike on the carrier so that it is balanced.

**NOTE:** Load bikes in the closest to the vehicle positions first. Load heavier bikes closer to the vehicle.

**NOTE:** The top plate flexes to secure different size frame tubes. Arrange similar size frame tubes next to each other.

**NOTE:** Each bike must be loaded onto the carrier with handlebars at opposite ends.

2. Place the top plate over the bikes with the threaded stud up through the center hole in the top plate. Install the plastic knob on the stud and tighten.

**NOTE:** The knob must be completely tightened to ensure bike stability on carrier.

**NOTE:** A 3/8" HOLE HAS BEEN PROVIDED IN THE TOP AND BOTTOM MOUNTING PLATES FOR USE WITH A CABLE AND PADLOCK, NOT INCLUDED.

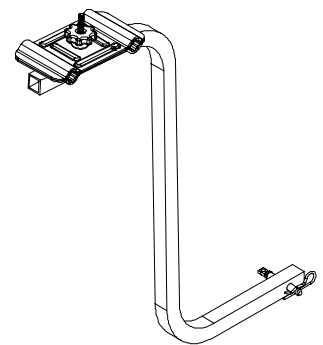

FIG 1

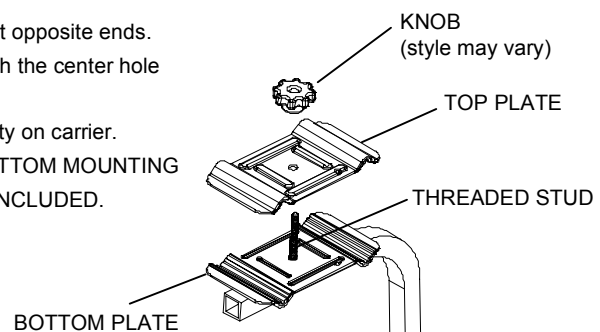
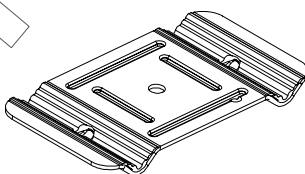

FIG 2

